



Specification :

- Size : 86mm(L) x 86mm(W) x 20mm(H)
- Current Rating : 3A@36VDC Max
- Operating Temp : 10 °C~ +55 °C
- Panel Material : Stainless Steel Panel
- Standard Structure : Stainless Steel Panel with Key
- Contact : COM, NC, NO, Tamp, -LED+
- Operating Humidity : 0 – 95%
- Weight : 0.18Kg

EL-KS3L

Technical Information :

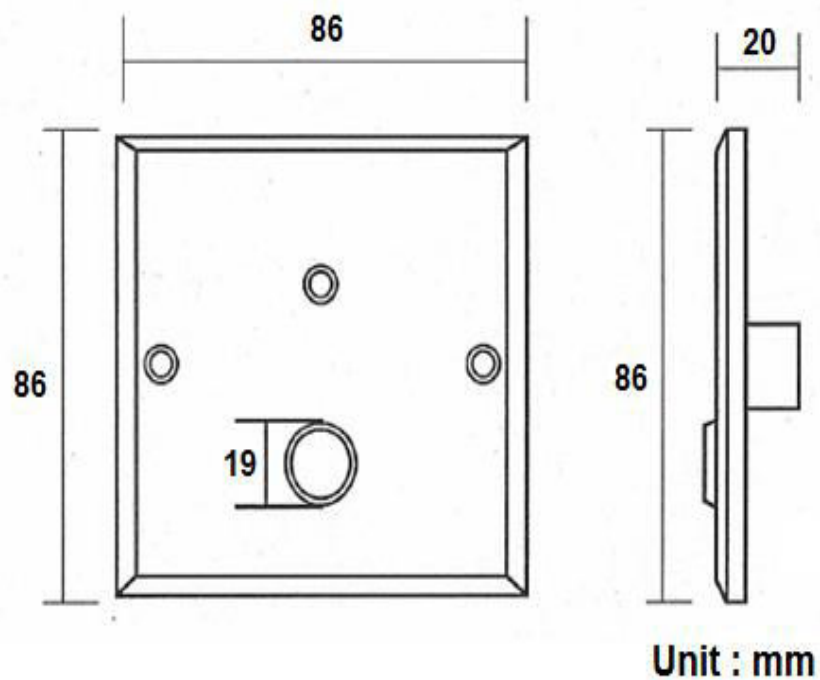

LED ON = Device is Functioning
LED OFF = Device is Not Functioning

